

| REVISIONS |     |                                  |          |       |
|-----------|-----|----------------------------------|----------|-------|
| ZONE      | LTR | DESCRIPTION                      | DATE     | APPD  |
|           | B   | REDRAWN & REVISED PER E.O. 18912 | 4-15-08  | L.B.O |
|           | C   | REVISED PER E.O. 19141           | 10-17-08 | Ja    |

THIS DOCUMENT CONTAINS PROPRIETARY INFORMATION AND EXCEPT WITH WRITTEN PERMISSION OF TRI-STAR ELECTRONICS INT'L, INC., SUCH INFORMATION SHALL NOT BE PUBLISHED, OR DISCLOSED TO OTHERS, OR USED FOR ANY PURPOSE, AND THE DOCUMENT SHALL NOT BE DUPLICATED IN WHOLE OR IN PART.

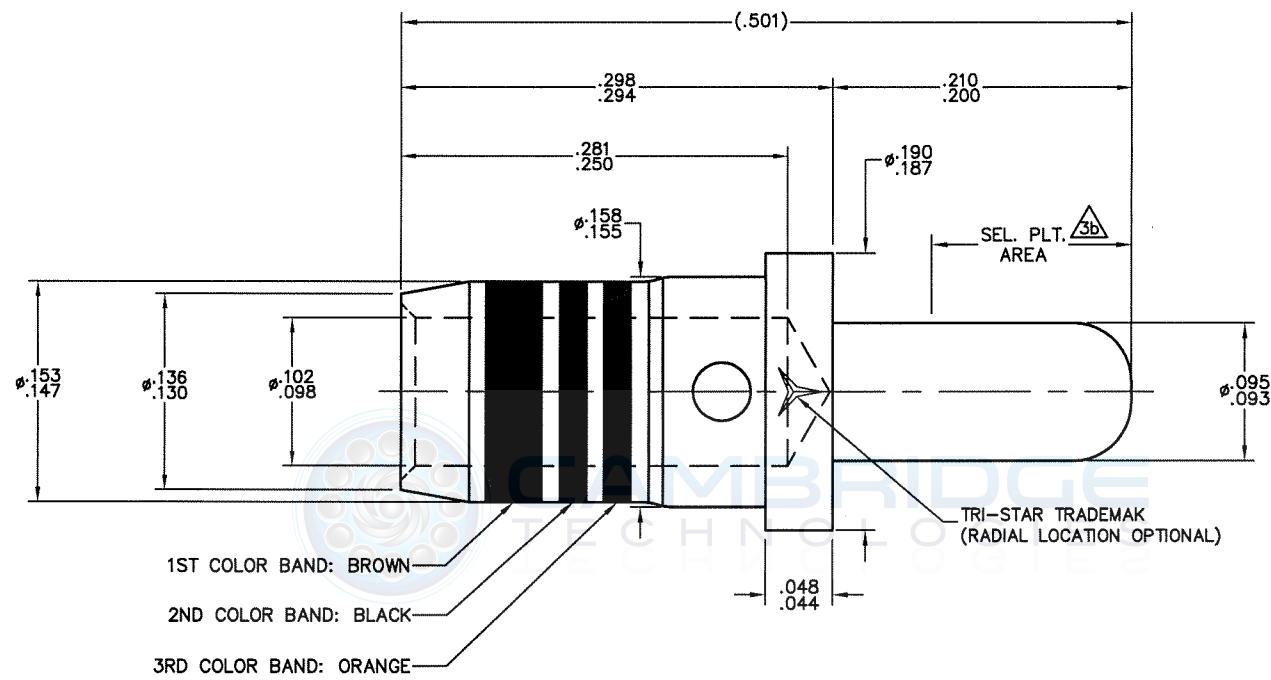

- 1ST COLOR BAND: BROWN
- 2ND COLOR BAND: BLACK
- 3RD COLOR BAND: ORANGE

- 6. SHEET 2 IS FOR TRI-STAR INTERNAL USE ONLY.
- 5. THIS PART MEETS ALL APPLICABLE REQUIREMENTS OF AS39029.
- 4. **CRIMP TOOL DATA:**

BASIC CRIMPING TOOL: M22520/1-01  
 POSITIONER: M22520/1-02 YELLOW.

**3 FINISH:** a). GOLD PLATE PER MIL-DTL-45204, TYPE-II, GRADE C, CLASS 1 (.000050 MIN). OVER .000050 MIN NICKEL PLATE PER AMS-QQ-N-290.

b). **OVERALL PLATING:** GOLD, STRIKE, PER MIL-DTL-45204, TYPE I, GRADE A OVER NICKEL PLATE PER AMS-QQ-N-290.

**SELECTIVE PLATING:** GOLD PLATE PER MIL-DTL-45204, TYPE II, GRADE C, CLASS 1. SELECTIVE PLATING AREA PER AS39029.

**2 MATERIAL:** SUITABLE COPPER ALLOY PER AS39029.

1. [www.tri-starelectronics.com](http://www.tri-starelectronics.com)

NOTES: (UNLESS OTHERWISE SPECIFIED)

TABLE-1

| MILITARY PART NUMBER | TRI-STAR PART NUMBER | FINISH |
|----------------------|----------------------|--------|
| M39029/1-103         | 315-1212-503         | 3a     |
|                      | 315-1212-503-L       | 3b     |

SALES DRAWING

| QTY REQD   | FORM NO. | PART OR IDENTIFYING NO. | NOMENCLATURE OR DESCRIPTION | MATERIAL SPECIFICATION | ITEM NO. |
|--|----------|-------------------------|-----------------------------|------------------------|----------|
|  |          |                         | PARTS LIST                  |                        |          |
| UNLESS OTHERWISE SPECIFIED DIMENSIONS ARE IN INCHES. TOLERANCES ARE: |          | CONTRACT NO.            |                             |                        |          |
| ANGLES ±30' .XX ±.01 .XXX ±.005                                      |          | RATING:                 |                             |                        |          |
| DO NOT SCALE DRAWING   |          | APPROVALS               |                             | DATE                   |          |
| MATERIAL: TREATMENT: FINISH:   |          | DRAWN: CHAPMAN          |                             | 4-1-80                 |          |
| REF: SEE TABLE-1   |          | CHECKED: J.V.G          |                             | 5-8-80                 |          |
| NEXT ASSEMBLY  |          | APPROVED: MORENO        |                             | 8-26-81                |          |
| USED ON  |          | SCALE: NONE CAD NO: 8X- |                             |                        |          |
| APPLICATION  |          | SHEET 1 OF 2            |                             |                        |          |

|   |  |   |  |   |  |
|---|--|---|--|---|--|
| UNLESS OTHERWISE SPECIFIED DIMENSIONS ARE IN INCHES. TOLERANCES ARE:<br>ANGLES ±30' .XX ±.01 .XXX ±.005<br>DO NOT SCALE DRAWING<br>MATERIAL: TREATMENT: FINISH: |  | CONTRACT NO.<br>RATING:<br>APPROVALS<br>DATE<br>DRAWN: CHAPMAN<br>4-1-80<br>CHECKED: J.V.G<br>5-8-80<br>APPROVED: MORENO<br>8-26-81 |  | TRI-STAR ELECTRONICS INT'L, INC.<br>2201 ROSECRANS AVENUE, EL SEGUNDO, CA 90245<br>CONTACT, ELECTRICAL CONNECTOR PIN, CRIMP REMOVABLE, #12<br>DWG TITLE<br>SIZE: A<br>CASE CODE: 55104<br>DWG NO.: 315-1212-503-*                 REV: C<br>SCALE: NONE CAD NO: 8X-<br>SHEET 1 OF 2 |  |
|---|--|---|--|---|--|