

THIS DOCUMENT CONTAINS PROPRIETARY INFORMATION AND EXCEPT WITH WRITTEN PERMISSION OF TRI-STAR ELECTRONICS INT'L, INC., SUCH INFORMATION SHALL NOT BE PUBLISHED, OR DISCLOSED TO OTHERS, OR USED FOR ANY PURPOSE, AND THE DOCUMENT SHALL NOT BE DUPLICATED IN WHOLE OR IN PART.

REVISIONS				
ZONE	LTR	DESCRIPTION	DATE	APPD
/	B	REVISED AND REDRAWN ON ACAD PER EO 11495	11-24-96	V.K.
/	C	REVISED PER E.O. 12580	9-18-98	B.H.
/	D	REVISED PER E.O. 16321	11-2-05	LBO
/	E	REVISED PER E.O. 17390	8-10-06	VTL
/	F	REVISED PER E.O. 19756	7-14-09	LBO
/	G	REVISED PER E.O. 19838	9-3-09	LBO
/	H	REVISED PER E.O. 21184	2/2/12	KLW

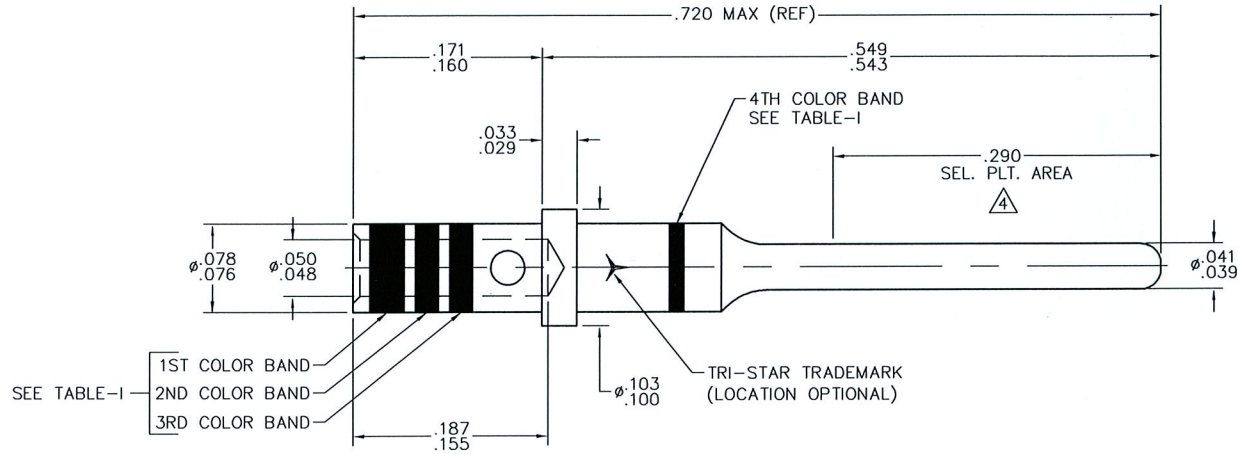

TABLE-I

AECMA REF. PART NUMBER	MILITARY PART NUMBER	TRI-STAR PART NUMBER	COLOR CODING	FINISH
EN3155-018M2020	M39029/4-110	315-2020-088	1 ST BAND: BROWN 2 ND BAND: BROWN 3 RD BAND: BLACK 4 TH BAND: RED	GOLD $\triangle 3$
EN3155-018P2020		315-2020-088R $\triangle 4$		
		315-2020-088-L		
		315-2020-088R-L $\triangle 4$		
		315-2020-088-7L		GOLD LOCALIZED $\triangle 4$

$\triangle 7$  PARTS SUPPLIED ON REEL (2000 CONTACTS) FOR USE IN A BUCHANAN CRIMP TOOL.

6. DELETED

5. CRIMP TOOL DATA:  
BASIC CRIMP TOOL - M22520/1-01  
POSITIONER - M22520/1-02 RED

$\triangle 4$  FINISH:  
OVERALL PLATING: GOLD STRIKE PER MIL-DTL-45204, TYPE IA OVER .000050 MIN NICKEL, PER AMS 2423.  
SELECTIVE PLATING: GOLD PLATE PER MIL-DTL-45204, TYPE II, GRADE C, (.000050 MIN THK) SELECTIVE PLATING AREA PER AS39029.

$\triangle 3$  FINISH: GOLD PLATE PER MIL-DTL-45204, TYPE II, GRADE C (.000050 MIN THK) OVER NICKEL PLATE PER AMS 2423.

$\triangle 2$  MATERIAL: SUITABLE COPPER ALLOY PER AS39029.

1. www.tri-starelectronics.com

NOTES: (UNLESS OTHERWISE SPECIFIED)

SALES DRAWING

QTY. REQD.	FROM NO.	PART OR IDENTIFYING NO.	HOMOLOGATION OR DESCRIPTION	MATERIAL SPECIFICATION	ITEM NO.
PARTS LIST					
UNLESS OTHERWISE SPECIFIED DIMENSIONS ARE IN INCHES. TOLERANCES ARE:		CONTRACT NO.			
ANGLES .XX .XXX .XXX		RATING:			
±.30 ±.01 ±.005		APPROVALS DATE			
DO NOT SCALE DRAWING		DRAWN: S. WOLDEN 11-26-96			
MATERIAL:	TREATMENT:	FINISH:	CHECKED: V. KAGEOROGIS 11-27-96		
$\triangle 2$		$\triangle 3$ $\triangle 4$	APPROVED: L. KERK 11-27-96		
REF:	REF:	REF:	SIZE: A	CAGE CODE: 55104	DWG NO.: 315-2020-088*-*
NEXT ASSEMBLY	USED ON	APPROVED:	SCALE:	CAD NO.:	REV: H
APPLICATION			SHEET 1 OF 1		

**TRI-STAR ELECTRONICS INT'L, INC.**  
2201 ROSECRANS AVENUE, EL SEGUNDO, CA 90245

DWG TITLE: CONTACT, ELECTRICAL CONNECTOR PIN, CRIMP REMOVABLE, #20