

THIS DOCUMENT CONTAINS PROPRIETARY INFORMATION AND EXCEPT WITH WRITTEN PERMISSION OF TRI-STAR ELECTRONICS INT'L, INC., SUCH INFORMATION SHALL NOT BE PUBLISHED, OR DISCLOSED TO OTHERS, OR USED FOR ANY PURPOSE, AND THE DOCUMENT SHALL NOT BE DUPLICATED IN WHOLE OR IN PART.

REVISIONS				
ZONE	LTR	DESCRIPTION	DATE	APPD
/	E	REVISED PER E.O. 20749	2/2/11	H.LE
/	F	REVISED PER E.O. 22133	5/13/13	K.C.
/	G	REVISED PER E.O. 22338	10/21/13	J.K.
/	H	REVISED PER E.O. 22689	6/30/14	K.C.
/	J	REVISED PER E.O. 23011	1/26/15	KL

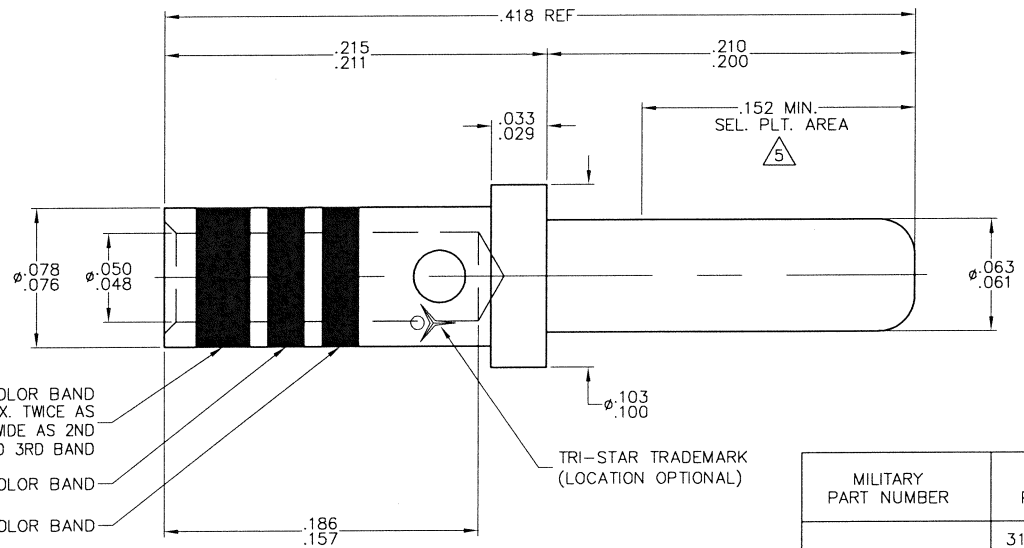

TABLE-I

MILITARY PART NUMBER	TRI-STAR PART NUMBER	COLOR CODING	FINISH
M39029/1-101	315-1620-501-L	1 ST BAND: BROWN 2 ND BAND: BLACK 3 RD BAND: BROWN	GOLD $\triangle 5$
	315-1620-501		GOLD $\triangle 3$
	315-1620-501-C		
	315-1620-501R		
NONE	319-1620-501	NONE	GOLD $\triangle 4$
	519-1620-501		
NONE	319-1620-501-L	NONE	GOLD $\triangle 5$

6. CRIMP TOOL DATA:  
 BASIC CRIMP TOOL: M22520/1-01 OR M22520/2-01  
 POSITIONER: M22520/1-02 RED OR M22520/2-11
- $\triangle 5$  FINISH:  
 OVERALL PLATING: GOLD STRIKE PER MIL-DTL-45204, TYPE I, OVER .000050 MIN. NICKEL PLATE PER AMS-QQ-N-290.  
 SELECTIVE PLATING: GOLD PLATE PER MIL-DTL-45204, TYPE II, GRADE C, (.000050 MIN THK) SELECTIVE PLATING AREA PER AS39029.
- $\triangle 4$  FINISH: GOLD PLATE PER MIL-DTL-45204, TYPE II, GRADE C, CLASS 2, (.000100 MIN) OVER .000050 MIN NICKEL PLATE PER AMS-QQ-N-290.
- $\triangle 3$  FINISH: GOLD PLATE PER MIL-DTL-45204, TYPE II, GRADE C, CLASS 1, (.000050 MIN) OVER .000050 MIN NICKEL PLATE PER AMS-QQ-N-290.
- $\triangle 2$  MATERIAL: SUITABLE COPPER ALLOY. PER AS39029.  
 1. www.carlisleit.com

SALES DRAWING

NOTES: (UNLESS OTHERWISE SPECIFIED)

REF.	DESCRIPTION	DATE
2	APPROVALS	DATE
3	APPROVED: S.M.	11-20-96
4	CHECKED: C.V.	12-5-97
5	APPROVED: B.H.	12-8-97

QTY REQD	FSCM NO.	PART OR IDENTIFYING NO.	NOMENCLATURE OR DESCRIPTION	MATERIAL SPECIFICATION	ITEM NO.
PARTS LIST					
UNLESS OTHERWISE SPECIFIED DIMENSIONS ARE IN INCHES. TOLERANCES ARE:		CONTRACT NO.		TRI-STAR ELECTRONICS INT'L, INC.	
ANGLES .XX ± .005		RATING:		2201 ROSECRANS AVENUE, EL SEGUNDO, CA 90245	
DO NOT SCALE DRAWING		APPROVALS		DWG TITLE	
MATERIAL: $\triangle 2$		DATE		CONTACT, ELECTRICAL CONNECTOR	
TREATMENT: $\triangle 3$		S.M. 11-20-96		PIN, CRIMP REMOVABLE, #16	
FINISH: $\triangle 4$		CHECKED: C.V. 12-5-97		SIZE	CAGE CODE
$\triangle 5$		APPROVED: B.H. 12-8-97		A	55104
REF.		APPROVED:		DWG NO.	REV
NEXT ASSEMBLY		APPROVED:		*1*-1620-501*-*	J
USED ON		APPROVED:		SCALE: NONE	CAD NO: 10X-
APPLICATION		APPROVED:		SHEET 1 OF 1	